

AE_83 Awesome EFIS



Table of Contents

Specs	3
Whats in the Box	4
Important Notes	5
Device Overview	6
Display Elements	7
Configuration	8
Mounting	11
Pitot / Static hookup	12
Wiring	13
Operation	15
Updating Firmware	17
RADbus	19
Connector Disassembly	20
Notes	21
Change log	23

Input Voltage

9-36 DC input voltage
<100mA at full brightness

Size and Weight

3.35" x 3.35" x 1.75"
125 grams

Max Airspeed

Low speed EFIS => 240 Mph (208 knots)
High speed EFIS => 340 Mph (295 knots)
Really high speed EFIS => 430 Mph (370 knots)

Max Altitude

30,000 ft

GNSS receiver w/ WAAS

Screen Size

2.8" 480x480 resolution

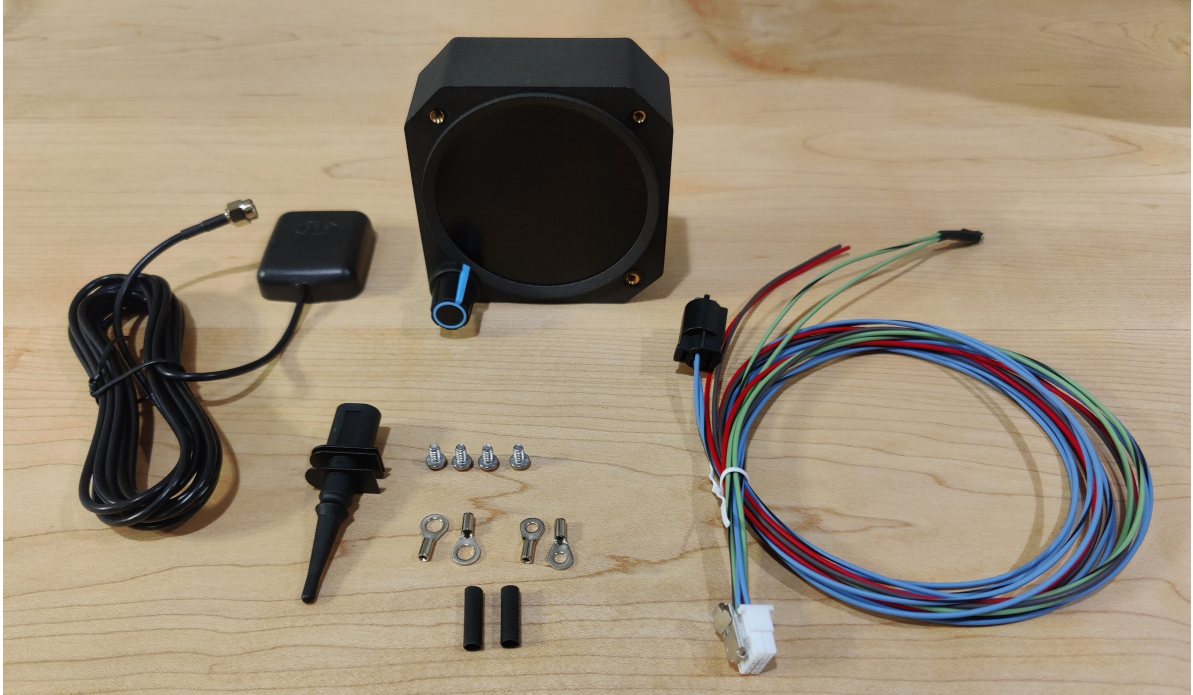

- => Awesome EFIS - AE_83
- => GNSS Antenna
- => Wiring Harness, terminated
- => Ring terminals(2 sizes) w/heat shrink
- => Outside Air Temperature Sensor
- => 4x Mounting Screws, 6-32x1/4"



Your AwesomeEFIS is shipped with the previous version of firmware, this is done to allow you to get familiar with updating the EFIS and verifying that no issues exist that would prevent you from updating the device in the future. Take a moment here to update your device before proceeding with the configuration(see pg 16).

NOTE => It is not recommended to power the EFIS without the GNSS antenna connected to avoid damaging the amplifier and input circuit.

NOTE => The USB-c connector is able to supply power to the EFIS for configuration and updating the firmware but it is not to be used to power the EFIS during aircraft operation.

NOTE => Voltage is not displayed when powered from USB.



Rotary encoder

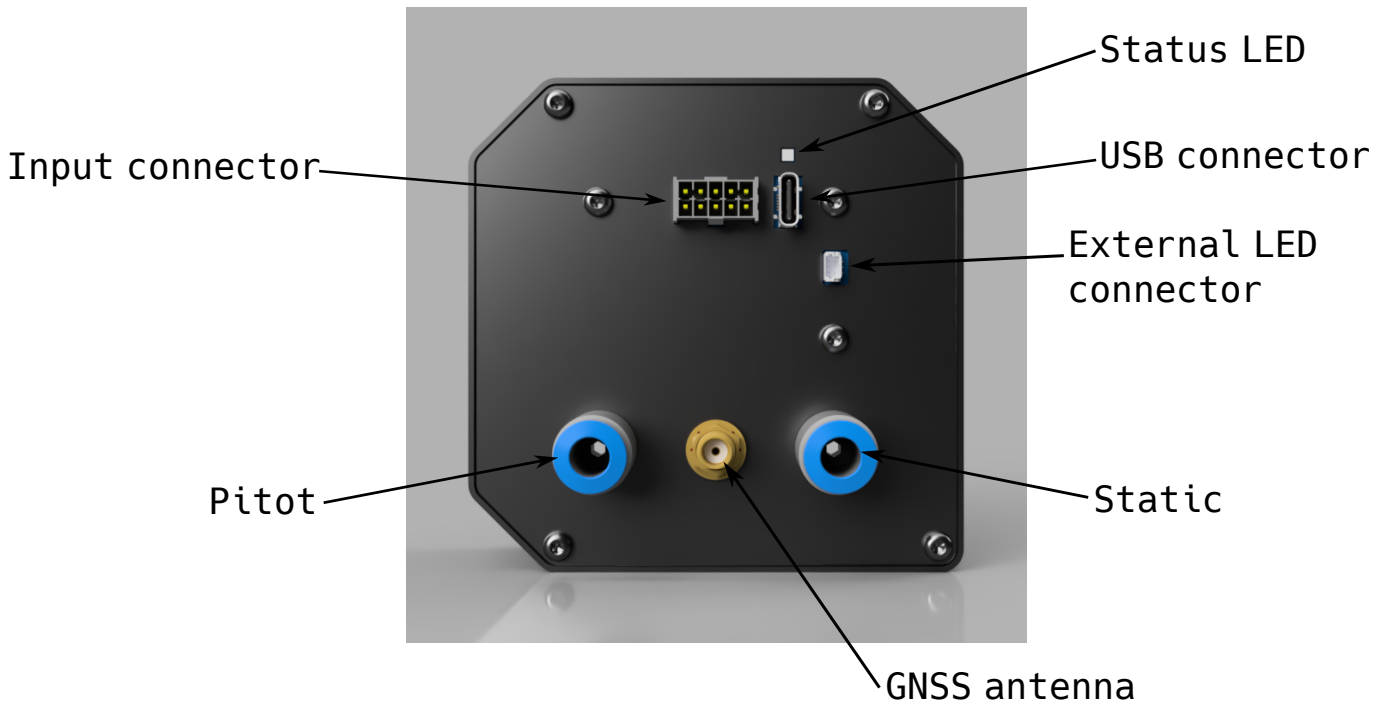

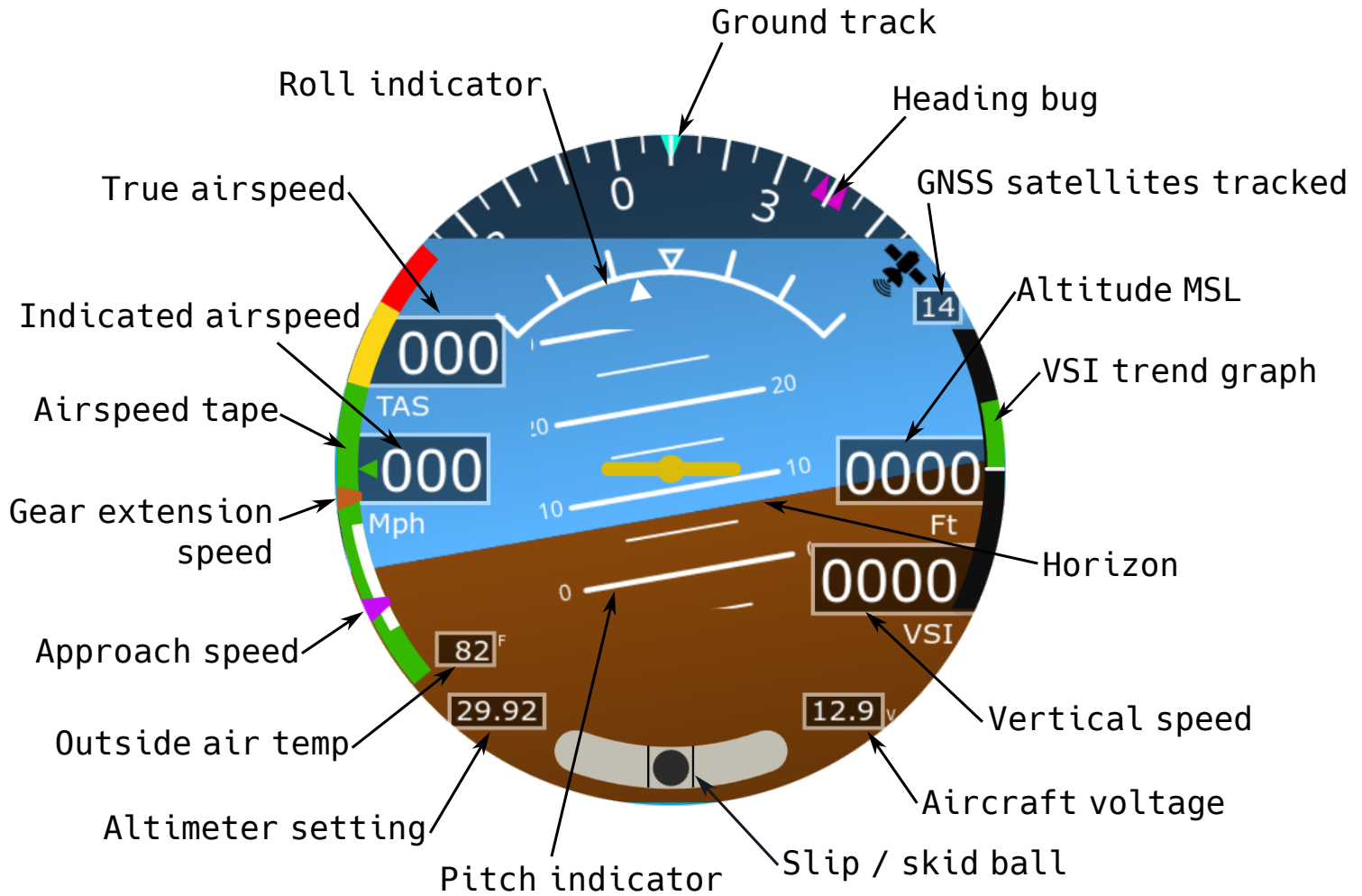

EFIS_Config runs on Windows 10(64-bit) or later and Linux.
MacOS version coming soon.

Connect the AwesomeEFIS to your PC via the USB-C connector on the back of the unit and launch the EFIS_Config application. The status bar at the bottom of the application will read "Configuration successfully loaded from device" and the default values should be displayed.

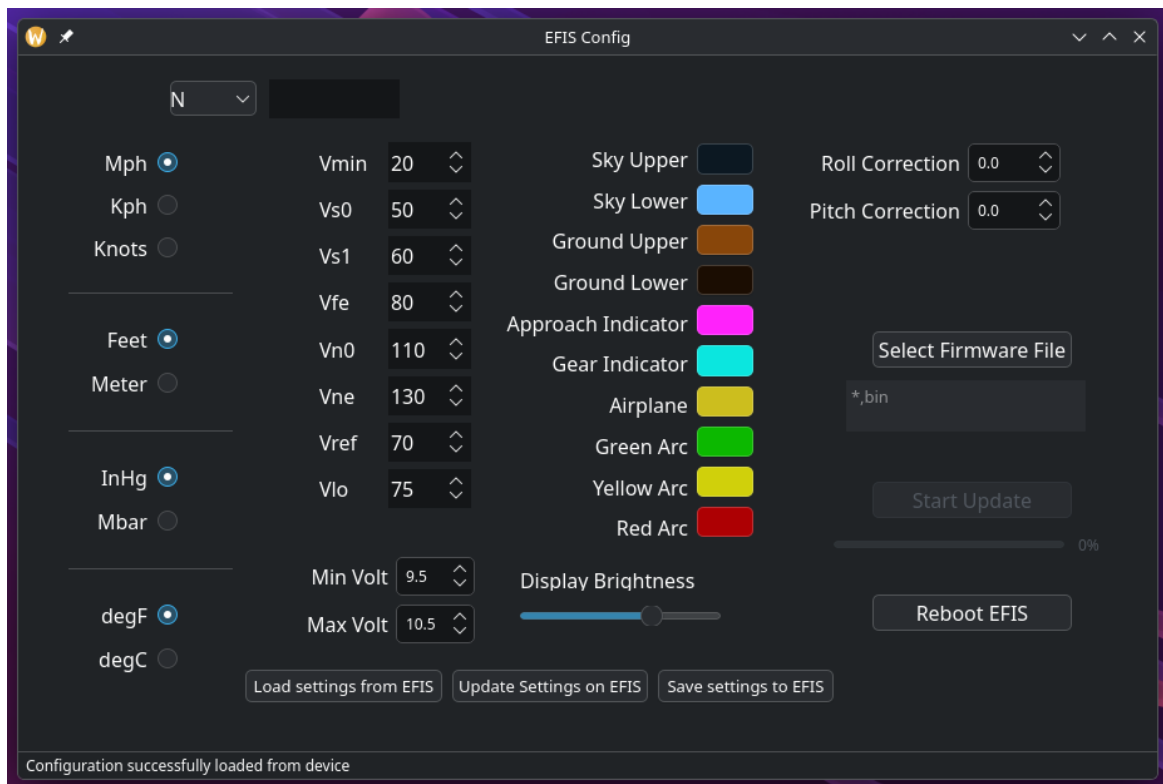

Loading / Updating / Saving Settings

"Update settings on EFIS" will send all of your configuration changes to the EFIS, where any changes will be displayed. The settings are not saved until the "Save settings to EFIS" button is clicked. To undo a configuration change that has not been saved you can simply press the "Load settings from EFIS" button and the settings will revert back to previous values.

Select the correct country code for your aircrafts registration from the dropdown and enter your tail number into the text box.

Set your desired units and adjust any of the colors to your liking by clicking on the colored box.

Bus Voltage Monitoring

The background color of the bus voltage will transition to **red** for a voltage measurement that is beyond the min / max alert levels set, and will transition to a **yellow** background if the voltage is between the warning volage level and the alert voltage level.

Min and Max volts will adjust the warning level at which point the the black background behind the voltage reading will turn red.

Installed Angle Correction

Roll and pitch correction can be used to zero the attitude that is displayed during straight and level flight to correct for variations between how the instrument is mounted relative to how the aircraft flies in a cruise configuration.

Perform a test flight and document the roll and pitch angles as shown on the EFIS. Enter those values in to the "Roll Correction" and "Pitch Correction" boxes, send changes to the EFIS and then save the changes to the EFIS.

Enter a positive angle if the EFIS was showing a nose high attitude, and a negative angle for a nose low attitude.

Enter a positive angle if the EFIS was showing left wing high attitude, and a negative value if it was showing right wing high.

V-Speeds

Enter the following speeds for your aircraft in the units you have selected.

- Vmin => When on the airspeed indicator screen, this will be first value displayed on the gauge.
- Vs0 => Bottom of the white arc. Set this to the aircrafts stall speed in the landing configuration(dirty stall).
Set Vs0 and Vfe values to 0 to disable the white arc.
- Vs1 => Bottom of the green arc. Set this to the stall speed(clean) or minimum steady flight speed.
- Vfe => Top of the white arc. Set this to the maximum flap extension speed
- Vn0 => Top of the green arc / bottom of the yellow arc. Set this to the maximum structural cruising speed.
- Vne => Top the Yellow arc / bottom of the red arc. Set this to the never exceed speed of the aircraft.
- Vref => Magenta indicator. Set to the approach speed of the aircraft in the landing configuration(typically 1.3x Vso). Set to 0 to disable this indicator.
- Vlo => Orange indicator. Set this to the aircrafts gear extension speed. Set to 0 to disable this indicator.

The EFIS mounts from behind the instrument panel into a standard 3 1/8" instrument opening. The encoder knob comes installed onto the rotary encoder, this pulls straight off. Behind the knob will be a nut and thin washer, these are to be removed before mounting the EFIS into the instrument panel.

Select the proper length 6-32 machine screws, mounting holes are 0.250" deep. Ensure screws do not bottom out in the mounting holes. 1/4" screws should work for most installations.

Once the instrument is mounted with the 3x mounting screws the nut and washer can be reinstalled on the the rotary encoder. The thin washer is optional and may be necessary to omit depending on the thickness of the instrument panel. Once the nut is secured on the rotary encoder the knob can be pressed back on. Ensure clearance between the instrument panel and the back of the knob to allow the rotary encoder button to be fully pressed.

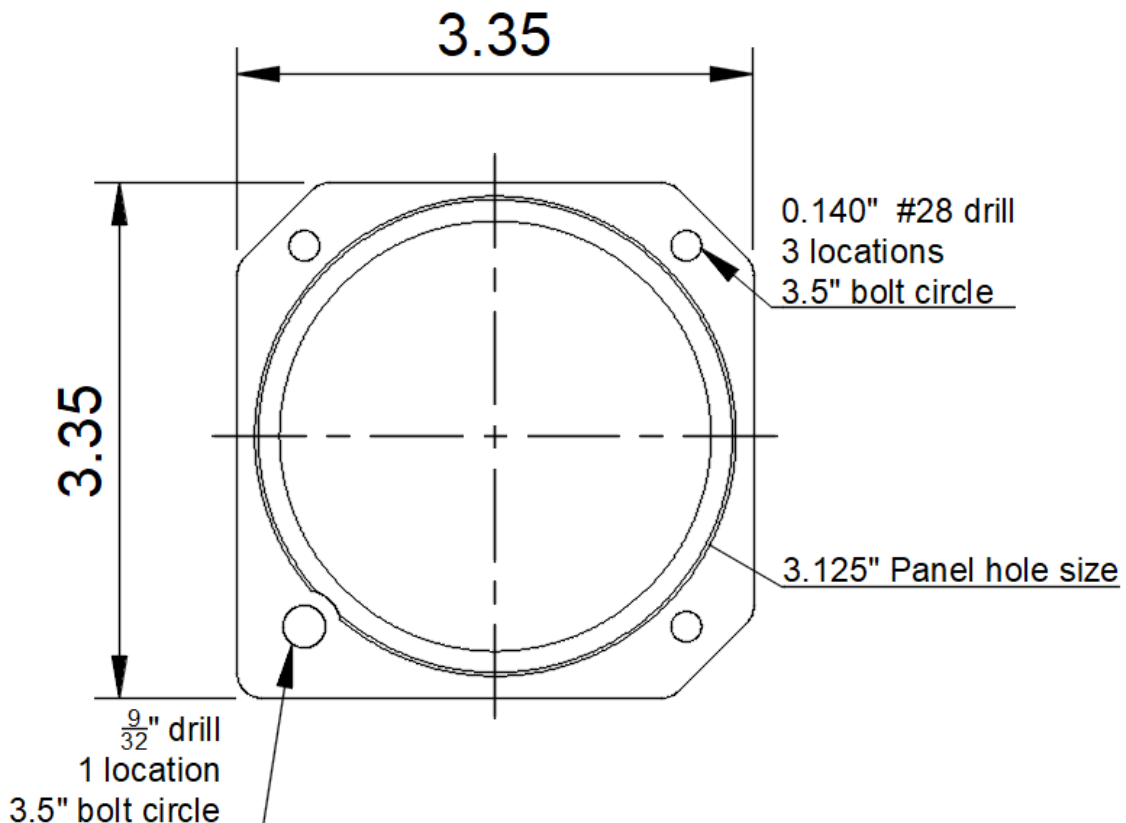

Pitot / Static

1/4" push to connect fittings are used to connect the AwesomeEFIS to your Awesome plane's pitot / static system.

Recommended tubing is 1/4" outside diameter, 5/32" inner diameter polyurethane rubber tubing. Ensure tubing is not metric (6mm) as the diameter is slightly smaller. Tubing may be purchased from McMaster Carr, part # 5648K25.

Barbed fittings may be used to adapt the 1/4" tubing to your aircraft's existing tubing.

Make sure the tubing end is cut off square, draw a reference line 5/16" (8mm) from the end of the tubing. Push the tubing into the fitting until you feel it bottom out, use the reference line to verify the tubing is fully inserted. A light pull of the tubing can be used to test the retention of the tubing into the fitting.

To remove the tubing from the fitting slide the gray release collar in towards the fitting and pull the back on the tubing, it should slide out freely.

NOTE => Always cut off the end of the tubing if it has been installed and removed from a fitting before reinstalling the tubing. Never reinstall a tube that has been previously installed without first trimming the end of the tubing off.

Power Supply

EFIS can be powered from any DC voltage source that is between 9–36v. The minimum required connections are power and ground on pins 1 & 6 and the GNSS antenna. Power device from a switched voltage source with a 1 amp circuit breaker or fuse.

The EFIS will automatically default to the DC power source if both USB and DC power source are available.

GNSS Antenna

Locate the GNSS antenna with a clear view of the sky, on top of the glare shield at the base of the windscreen is a simple and effective location. A skylight or window are also acceptable locations. Satellite reception will be reduced if the top of the antenna is shielded by a metal panel (IE mounted under the glare shield).

Outside Air Temperature

An outside air temperature sensor is included and pre-terminated to pins 3 & 8. See page 19 for information on de-pinning the connector to allow passing the wires through a bulkhead.

USB

It is recommended to leave a USB-C cable connected to the rear of the EFIS with the loose end secured behind the instrument panel. Allow yourself easy access to the loose end of the cable for future firmware updates. 3-4" behind the instrument, secure the USB cable to main EFIS wiring harness use waxed lacing cord or a cable tie to provide added strain relief.

Pin	Function	Color
1	Voltage supply, switched	Red
2	RADbus high	Green
3	OAT return	Blue / Black
4	No connect	
5	AUX 1	
6	Ground	
7	RADbus low	Green / Black
8	OAT supply	Blue
9	No connect	
10	Ground	Brown

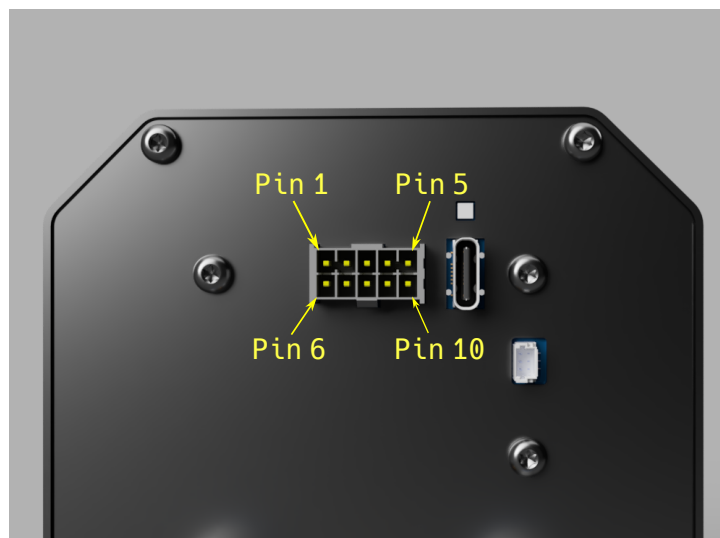

The EFIS will startup on the main AHRS screen, additional screens can be viewed by double clicking the rotary encoder quickly. Screens will cycle through in the following order...

- => AHRS
- => ADS-B / Map
- => Airspeed
- => Altimeter

The rotary encoder can have different functionality depending on the current screen that is displayed, operation of each screen is detailed below.

AHRS and Altimeter Screens

Rotating the rotary encoder will adjust the altimeter setting, the altitude is adjusted in real time as the altimeter setting is changed. You will notice the altimeter setting turns yellow when adjusted, this signifies that that the altimeter setting has changed but is not activated. A short press of the encoder will activate the selected altimeter setting and the text will turn back to white.

ADS-B / Map Screen

Rotating the rotary encoder will adjust the zoom of the display. The radius of the distance rings is displayed in miles.

Attitude / Heading Reference System (AHRS)

The AHRS is disabled until a stable GNSS 3d fix is acquired, until the AHRS is activated the horizon will not update with the attitude of the aircraft. A red GNSS satellite indicates no 3d fix. With the aircraft outside and a clear view of the sky you can expect a full 3d fix in under a minute. Once a 3d fix is established the GNSS satellite indicator will change to white, the AHRS will activate, and the horizon will update with changes to aircraft attitude. The number of tracked GNSS satellites is displayed near the lower right corner of the GNSS satellite indicator, a properly placed antenna will result in tracking at least 20 satellites.

Traffic and airports will not be displayed on the ADS-B screen until a valid 3d fix is acquired.

Updates are performed over USB using the EFIS_config application or optionally over RADbus using a USB-canFD interface.

The latest firmware is available from www.RAD-aero.com, download the RAD_AE83_vX.X.X.bin file and save it to disk.

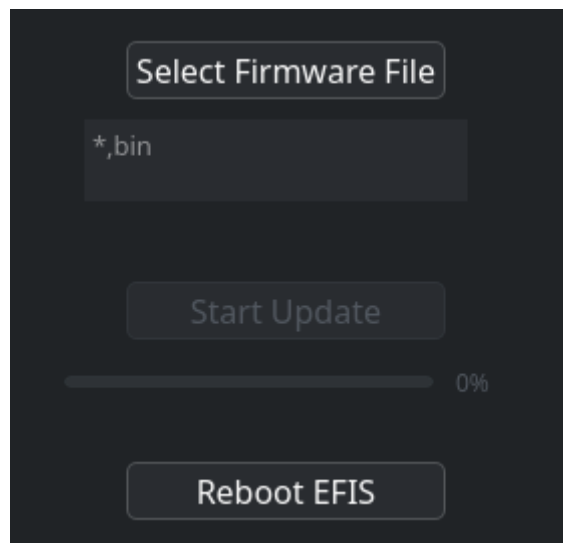

Click on the "Select Firmware File" button and navigate to where you have saved the firmware file. Click that "Start update" button to begin the update. The progress bar will quickly progress to 100% reset to 0% and then progress to 100% once again. The first pass is erasing the memory partition that will hold the firmware file and the second pass will send the firmware to the device. The status bar at the bottom of the window will indicate a successful transfer.

The new firmware will be installed automatically the next time the EFIS boots. Pressing the "Reboot EFIS" button will do just that. A progress bar will be displayed on the EFIS during the installation process. The device will automatically reboot once more and the installation will be complete!

Bootloader Operation

A custom robust bootloader is being used to manage firmware updates. The 2 most recent firmware files are kept on the device, in the event of a failed firmware update the device will automatically roll back to the previous firmware version.

Firmware images are encrypted and use multiple checksums to ensure the update will succeed and prevent manipulation of the software.

The multistage bootloader has been designed to never leave you with a "bricked" device, we will be able to restore the firmware.

RADbus

RADaero devices communicate over a CAN FD based network using a custom message protocol designed for reliability, performance and security. Messages are broadcast across a shared bus, allowing multiple devices to exchange data simultaneously – no master controller required.

Every message is tagged with an identifier that defines both its purpose and priority, ensuring time-critical data cuts through instantly while lower-priority traffic falls in line.

If a single RADaero device is being installed leave the RADbus high and RADbus low wires disconnected.

If multiple devices are being installed connect all RADbus high wires together, and all RADbus low wires together.

RADbus termination resistors are installed in every device and are enabled / disabled via the configuration application. Termination resistors should only be enabled on 2 devices, with all other devices set to disable the termination resistors.

OAT Sensor Connector

Slide the green contact retainer to the prelocking position. This will expose 2 windows that you will be able to see the contact through. Use a small pick or tweezers to depress the contact locking barb while gently pulling the wire out of the housing.

To reassemble push the contact into the housing until it locks into place, slide the green retainer to the locked position.

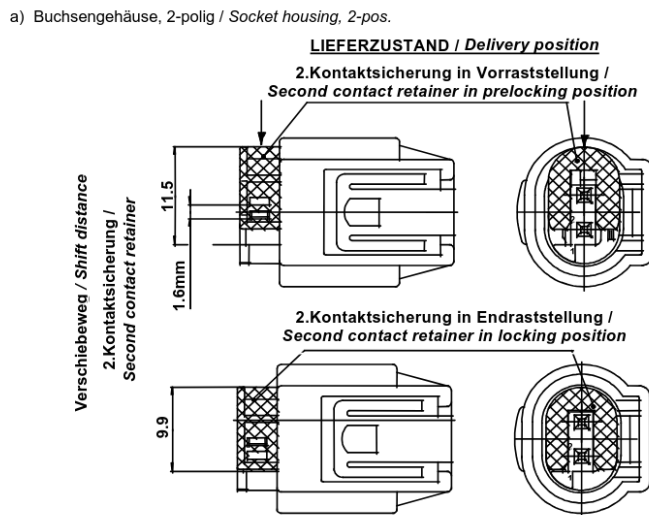

2.Kontaktsicherung wie angegeben verschieben und verrasten (1 Rastnoppen)
 Slide and lock the second contact retainer as shown (1 locking knob)



Release windows



Locking Barb





Firmware Version

- => **v0.2.9**
 - => Altimeter, Airspeed, ADS-B screens added
 - => UAT traffic support added
- => **v0.2.8**
 - => Added RADbus ADS-B framework
- => **v0.2.5**
 - => Initial Release

Configuration App

- => **v0.2.1**
 - => Added bus voltage warning levels and alert levels
 - => Moved firmware updates to new tab
- => **v0.2.0**
 - => Initial Release

This Document

- => **v0.3**
 - => Added operation of additional screens
 - => Additional information on roll / pitch correction
 - => Additional information on bus voltage monitoring
- => **v0.2**
 - => Initial Release



Limited Hardware Warranty

The manufacturer warrants that this product will be free from defects in materials and workmanship under normal use for a period of two (2) years from the date of original purchase. During the warranty period, the manufacturer will, at its sole discretion, repair or replace any product that is determined to be defective. Replacement products may be new or refurbished and will be functionally equivalent to the original product.

This warranty applies only to the original purchaser and is non-transferable.

Warranty Exclusions

This warranty does not cover damage or failure resulting from:

- Improper installation, wiring, or configuration
- Use outside the product's specified electrical, mechanical, or environmental limits
- Modification, disassembly, reverse engineering, or unauthorized repair
- Exposure to moisture, chemicals, excessive heat, vibration, or mechanical stress
- Power surges, improper grounding, electrostatic discharge (ESD), or lightning
- Software, firmware, or configuration errors not supplied by the manufacturer
- Normal wear and cosmetic damage
- Use of the product in any application for which it was not designed or intended

Consumable components and accessories, if any, are excluded unless otherwise stated.

Disclaimer of Implied Warranties

Except for the express limited warranty stated above, the product is provided "as is" and all other warranties are disclaimed, whether express, implied, or statutory, including but not limited to: Implied warranties of merchantability, Implied warranties of fitness for a particular purpose, Any warranties arising from course of dealing or usage of trade.

Limitation of Liability

To the maximum extent permitted by law, the manufacturer shall not be liable for any indirect, incidental, special, consequential, or punitive damages, including but not limited to: Loss of use, Loss of data, Loss of profits or revenue, Cost of substitute equipment, Downtime or operational delays.

This limitation applies regardless of the legal theory under which liability is asserted, whether in contract, tort (including negligence), strict liability, or otherwise. The manufacturer's total cumulative liability, for any claim arising out of or related to the product, shall not exceed the original purchase price of the product.

Safety-Critical Use Disclaimer

This product is not certified for use as a primary flight instrument or for any application requiring fail-safe, fault-tolerant, or life-critical operation, unless explicitly stated otherwise.

The user acknowledges that:

The product may fail or provide erroneous data

Redundant systems and independent verification are required for safety-critical use

The manufacturer is not responsible for decisions made based on the product's output

Use of this product is entirely at the user's own risk.

Software and Firmware Disclaimer

Any software or firmware provided with the product is supplied "as is", without warranty of any kind. The manufacturer does not warrant that the software will be error-free, uninterrupted, or compatible with all systems. Updates, modifications, or third-party software integrations may affect functionality and are not covered under warranty.

Governing Law

This warranty and any disputes arising from the use of the product shall be governed by and construed in accordance with the laws of the State of Oklahoma, without regard to conflict-of-law principles.